

in[mm]

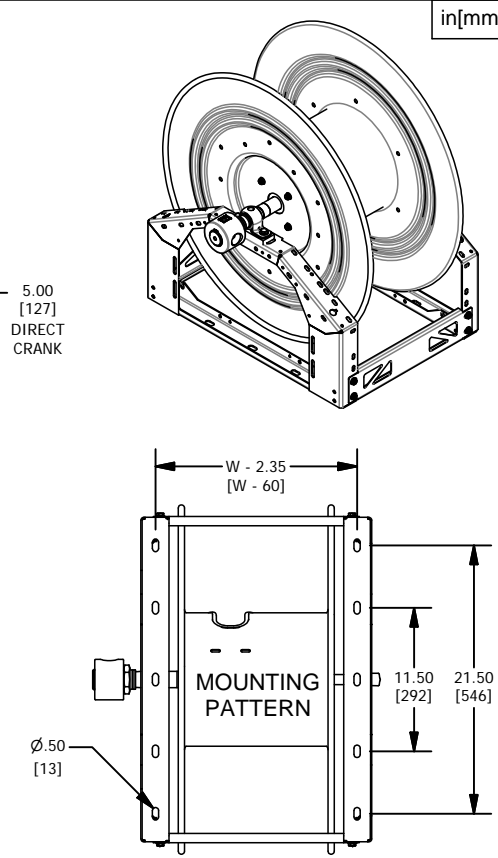
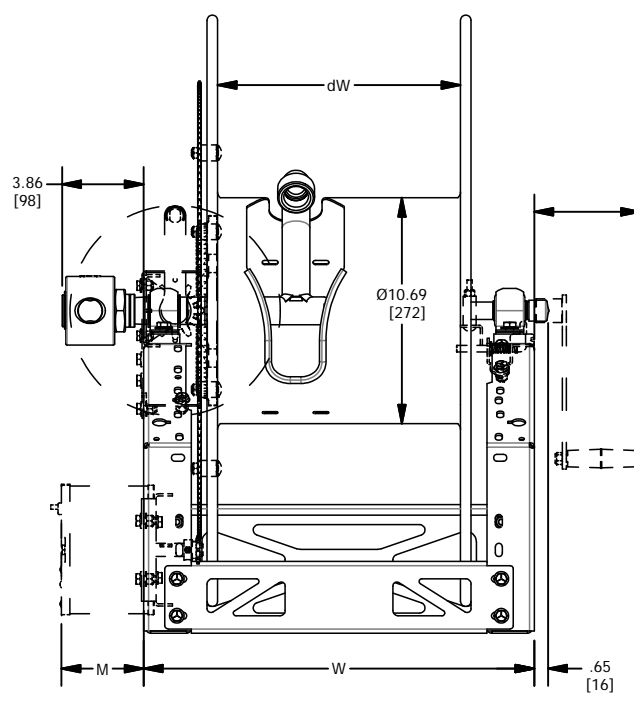
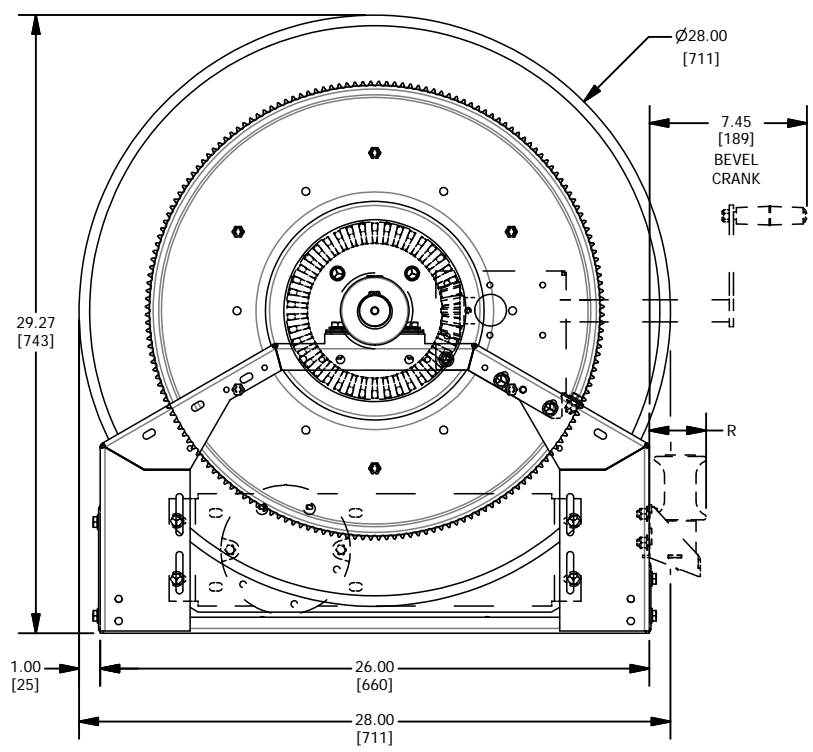

| DIMENSION M in[mm] | | | | | |
|--|--------------|--------------|------------|------------------|--|
| MOTOR DRIVE SYSTEM | DIRECT DRIVE | + IDLER GEAR | + CLUTCH | + IDLER & CLUTCH | DRIVE OPTIONS |
| ELECTRIC MOTOR: 1/3 HP (12VDC,24VDC) | 4.25 [110] | 5.00 [130] | 4.25 [110] | 5.00 [130] | IDLER GEAR 1:2, 1:3, 1:4 RATIO CENTRIFUGAL CLUTCH EXTERNAL SHAFT FOR BRAKES (ELECTRO-MAG. OR 3-WAY BRAKE) |
| ELECTRIC MOTOR: 1/2 HP (12VDC,24VDC,115VAC,230VAC) | 6.00 [150] | 6.88 [175] | 6.88 [175] | 7.88 [200] | |
| AIR MOTOR (4 VANE, ALUMINUM) | 3.13 [80] | 4.13 [105] | - | - | EXTERNAL SHAFT FOR BRAKES |
| AIR MOTOR (6 VANE, IRON) | 4.75 [120] | - | - | - | - |
| HYDRAULIC | 2.88 [75] | 3.75 [95] | - | - | EXTERNAL SHAFT FOR BRAKES |

| DIMENSION R in[mm] | |
|-------------------------|-----------|
| ROLLER TYPE | DIM "R" |
| 4-WAY ROLLERS | .82 [21] |
| UNIVERSAL 4-WAY ROLLERS | 1.21 [31] |
| 3-WAY ROLLERS | 2.76 [70] |
| UNIVERSAL 3-WAY ROLLERS | 3.15 [80] |

| MATERIAL SPECIFICATIONS | | |
|-------------------------|----------------------------|--------------------------------|
| COMPONENT | MATERIAL | OPTIONS |
| PLUMBING | ZINC PLATED STEEL | 316 STAINLESS STEEL |
| SWIVEL | NI PLATED STEEL | 316 STAINLESS STEEL |
| SEALS | NITRILE | VITON, EPDM |
| REEL | STEEL | - |
| BEARINGS | BRONZE, SELF LUBE | - |
| DRAG BRAKE | NYLON | BRAKE PAD MATERIAL |
| CHAIN GUARD | STEEL | ABS |
| FINISH | BLUE POLYESTER POWDER COAT | RED, GREEN, WHITE, BLACK, GREY |

| MODEL | dW in[mm] | W in[mm] | 1" (1.44" OD) CAPACITY ft[m] | 3/4" (1.25" OD) CAPACITY ft[m] | SHIPPING WEIGHT lb[kg] |
|-----------|------------|------------|------------------------------|--------------------------------|------------------------|
| 1660-0828 | 8 [200] | 15 [380] | 125 [40] | 175 [50] | 83 [38] |
| 1660-0928 | 9.5 [240] | 16.5 [420] | 165 [50] | 225 [65] | 85 [39] |
| 1660-1128 | 11.5 [290] | 18.5 [470] | 200 [60] | 275 [80] | 88 [40] |
| 1660-1328 | 13.5 [340] | 20.5 [520] | 225 [68] | 325 [100] | 91 [41] |
| 1660-1528 | 15.5 [390] | 22.5 [570] | 250 [75] | 375 [115] | 94 [43] |
| 1660-2028 | 20 [510] | 27 [690] | 350 [100] | 500 [150] | 100 [45] |
| 1660-2228 | 22 [560] | 29 [740] | 400 [120] | 550 [165] | 103 [47] |
| 1660-2428 | 24 [610] | 31 [790] | 450 [135] | 600 [180] | 106 [48] |
| 1660-2528 | 25 [640] | 32 [815] | 485 [145] | 625 [190] | 108 [49] |
| 1660-2828 | 28 [710] | 35 [890] | 535 [160] | 700 [210] | 113 [51] |
| 1660-3328 | 33 [840] | 40 [1020] | 625 [190] | 800 [250] | 121 [55] |

PART NUMBER

DRUM WIDTH — DISK SIZE — ROLLERS & SETUP
COLOR —

16 60 - 15 28 - XX - B X XX

PLUMBING SIZE: 60 = 1", 80 = 1.5"
MOTOR, CRANK & BRAKE OPTIONS
PLUMBING & SWIVEL OPTIONS

| SPECIFICATIONS | | |
|----------------|---------------------------------|---|
| FEATURE | SPEC. | OPTION |
| PRESSURE | 4000 PSI [275 BAR] | - |
| TEMPERATURE | -40 F TO 275 F [-40 C TO 135 C] | -60 F [-51 C] EPDM 400F [240 C] VITON |
| INLET THREAD | 1" NPT FEMALE | 1" BSPT FEMALE |
| OUTLET THREAD | 1" NPT FEMALE | 1" NPT MALE, BSPP FEMALE, BSPT MALE, NST |

UNLISTED OPTIONS & CUSTOM REELS

NOT ALL OPTIONS ARE LISTED, CONTACT YOUR SALES REPRESENTATIVE OR FACTORY FOR ADDITIONAL OPTIONS & CUSTOM MODIFICATIONS

COXREELS

5865 S Ash Avenue Tempe, Az 85283
1-800-COX-REEL www.coxreels.com

THIS DOCUMENT CONTAINS PROPRIETARY INFORMATION AND IS THE PROPERTY OF COXREELS, INC. THE COPYING, DISTRIBUTION AND UTILIZATION OF THIS DOCUMENT AS WELL AS COMMUNICATION OF ITS CONTENT TO OTHERS WITHOUT THE WRITTEN AUTHORIZATION OF COXREELS, INC., IS PROHIBITED.

TITLE: 1600 SERIES, 28" DISK, 1" PLUMBING

| | |
|---------------------|--|
| DWG. NO.: 1660-XX28 | REV. A |
| 3RD ANGLE | INTERPERT PER ASME : Y14.5M-1994 DO NOT SCALE DWG. |
| | SIZE: A SHT:1 OF:2 |

ROLLER BRACKET OPTIONS

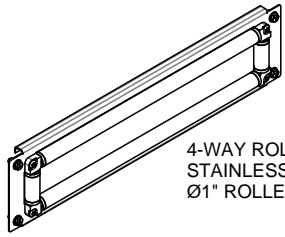

4-WAY ROLLERS
STAINLESS STEEL
Ø1" ROLLERS

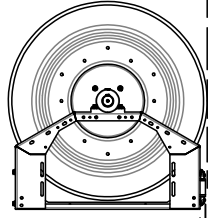

BOTTOM
4-WAY ROLLERS
←.74
[19]

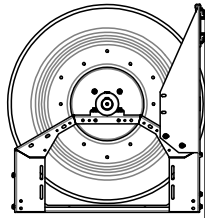

TOP
4-WAY ROLLERS
←.82
[21]

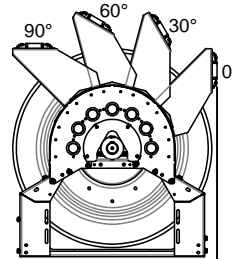

UNIVERSAL
4-WAY ROLLERS
←1.75
[44]

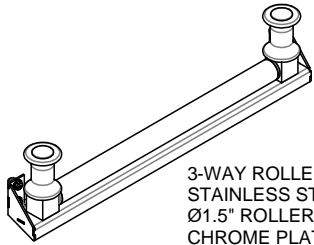

3-WAY ROLLERS
STAINLESS STEEL
Ø1.5" ROLLER
CHROME PLATED
STEEL SPOOLS

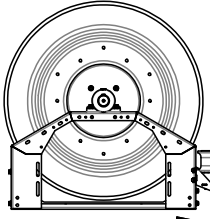

BOTTOM
3-WAY ROLLERS
←2.69
[68]

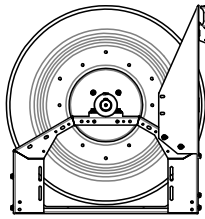

TOP
3-WAY ROLLERS
←2.76
[70]

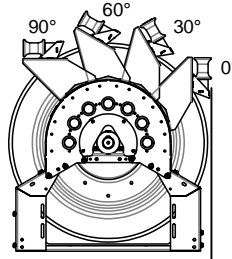

UNIVERSAL
3-WAY ROLLERS
←1.53
[39]

BEVEL CRANK UNIVERSAL OPTION

UNIVERSAL BEVEL CRANK MOUNT
ALLOWS FOR VARIOUS ANGLES
WORKS WITH OR WITH OUT 3 OR 4
WAY ROLLERS

in[mm]

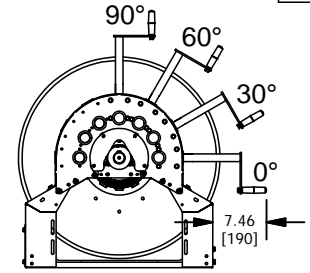
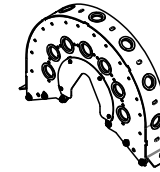

BEVEL CRANK HANDLE HOLSTER

HOLSTER INCLUDES RETAINING
PIN FOR AUXILIARY CRANKS &
MOUNTS TO ANY BEVEL MOUNT
BRACKET & DIRECTLY TO FRAME

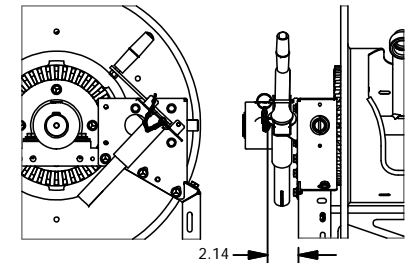
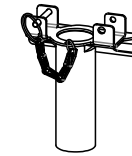

GUARDING OPTIONS

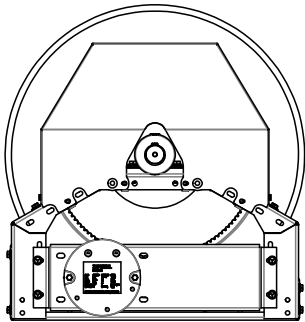

ABS FORMED OR METAL CHAIN &
BEVEL GEAR GUARDS DEPENDING
ON SPROCKET SIZE

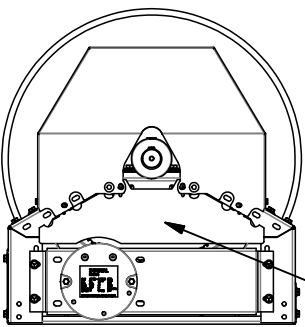
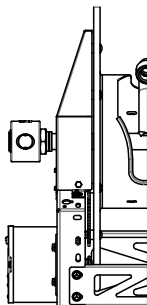

LOWER CHAIN GUARD COVERS
ACCESS TO CHAIN FROM OUTSIDE
AND INSIDE OF FRAME

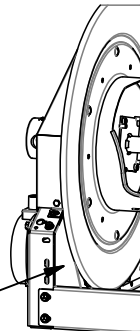

3-WAY PIN LOCK

(3 POSITION HEAVY DUTY PIN LOCK)

PATENT PENDING

¾" SOLID STEEL PIN
LOCKING EVERY 20°
EXTERNAL GREASE FITTING

3 POSITIONS

- 1) LOCKED REEL
- 2) FREE SPIN
- 3) LEVER ACTIVATED REWIND
(TRIGGERS ELECTRIC MOTOR REWIND)

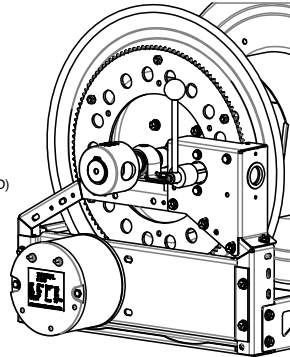
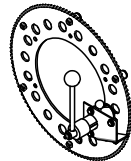

CONTROL BOX

(NEMA 1 ENCLOSED ELECTRICAL BOX)

12VDC OR 24VDC
CIRCUIT BREAKER
MOTOR SOLENOID
MOMENTARY SWITCH
WIRE STRAIN RELIEFS

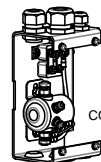

SHOWN WITH
COVER REMOVED

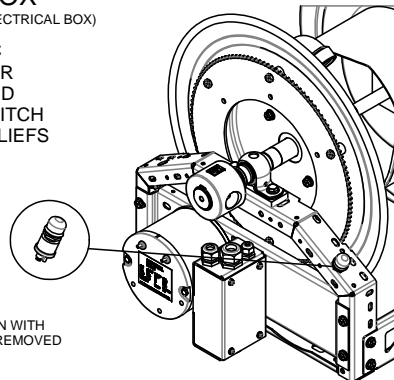

BRAKE UPGRADES

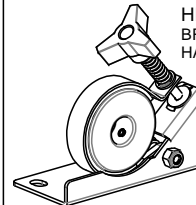

HEAVY DUTY BAND BRAKE
BRAKE PAD LINED BAND
HARDENED STEEL DRUM

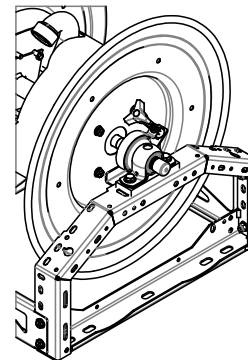

HEAVY DUTY
BAND BRAKE

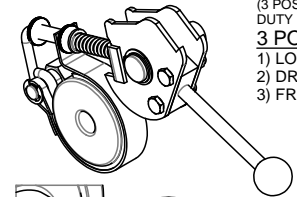

3-WAY BRAKE
(3 POSITION HEAVY
DUTY BAND BRAKE)
3 POSITIONS
1) LOCK REEL
2) DRAG BRAKE
3) FREE SPIN

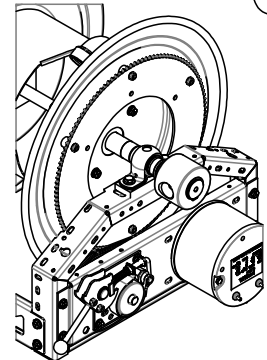

3-WAY BRAKE
ON IDLER SHAFT

COXREELS

5865 S Ash Avenue Tempe, Az 85283
1-800-COX-REEL www.coxreels.com

THIS DOCUMENT CONTAINS PROPRIETARY
INFORMATION AND IS THE PROPERTY OF COXREELS,
INC. THE COPYING, DISTRIBUTION AND UTILIZATION
OF THIS DOCUMENT AS WELL AS COMMUNICATION
OF ITS CONTENT TO OTHERS WITHOUT THE WRITTEN
AUTHORIZATION OF COXREELS, INC., IS PROHIBITED.

TITLE: **1600 SERIES, OPTIONS &
ACCESSORIES**

| | | | |
|-----------|--|---------|------------|
| DWG. NO.: | 1600-XX28 | REV. | A |
| 3RD ANGLE | INTERPERT PER ASME : Y14.5M-1994 DO NOT SCALE DWG. | SIZE: A | SHT:2 OF:2 |